

Pure DC® Universal Power Supply - Installation Instructions

Model: PS-UNI-PR-96-24

Please read all instructions prior to installation and keep for future reference!

This LED Driver is to be installed in accordance with Article 450 of the National Electrical Code. The LED Driver must be installed in a well ventilated area and free from explosive gases and vapors. Proper operation requires the free flow of air as this LED Driver is hardwired, it should only be installed by a qualified electrician. Suitable For Pool and Spa Rated Locations. Installation must also comply with provisions of the National Electric Code, ANSI/NFPA 70, including those in Article 680 - Swimming Pools, Fountains, and Similar Installations.



REVO.3
01182024

1 / 2



7777 Merrimac Ave
Niles, IL 60714
T 224.333.6033
F 224.757.7557
info@luminii.com
www.luminii.com

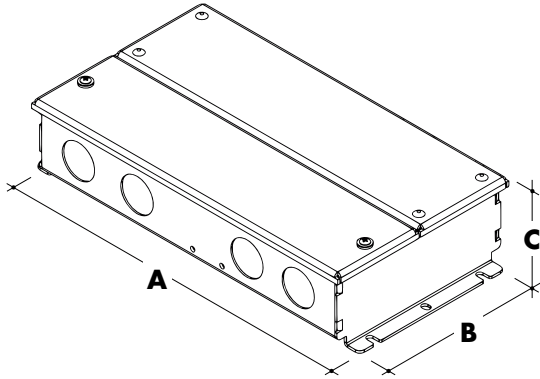

MODELS	PS-UNI-PR-96-24
MAX Load	96 watts
A. Length	8.71"
B. Width	4.56"
C. Depth	1.86"
Net Weight	3.5 lbs

1

Before installing, check the label and ensure the LED Driver has the proper input voltage, output voltage, and wattage for the job. Check the wire markings to ensure they match the wiring diagram below. Refer to table above for the maximum loads!

1.1 With a minimum of 2" clearance around power supply to provide proper air circulation.

1

1.2 Power supply must be placed 5 feet horizontally away from the inside walls of the pool unless separated from the pool by a solid fence, wall, or other permanent barrier.

2

2.1 Remove the two Phillips screws from the top of the driver housing and pull the cover off to expose the driver wires.

3

3.1 Insert the 120-277 VAC power into the driver housing from the electrical panel. Followed by bringing the 24V DC low voltage wires from the LEDs into the driver housing. In addition bring the controller wire if applicable. Refer to diagram on page 2 to make all the proper wiring connections.

Pure DC® Universal Power Supply - Installation Instructions

Model: PS-UNI-PR-96-24



7777 Merrimac Ave
Niles, IL 60714
T 224.333.6033
F 224.757.7557
info@luminii.com
www.luminii.com

REVO.3
01182024

2 / 2

Please read all instructions prior to installation and keep for future reference!

This LED Driver is to be installed in accordance with Article 450 of the National Electrical Code. The LED Driver must be installed in a well ventilated area and free from explosive gases and vapors. Proper operation requires the free flow of air as this LED Driver is hardwired, it should only be installed by a qualified electrician. Suitable For Pool and Spa Rated Locations. Installation must also comply with provisions of the National Electric Code, ANSI/NFPA 70, including those in Article 680 - Swimming Pools, Fountains, and Similar Installations.

4

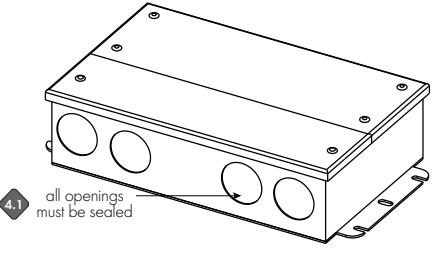

4.1 Make sure that all knockouts and openings are properly sealed or closed with acceptable plugs.

4 **WIRING DIAGRAM**

PS-UNI-PR-96-24

Note: Over the white, green and black wires, connect to ELV and MLV dimmer

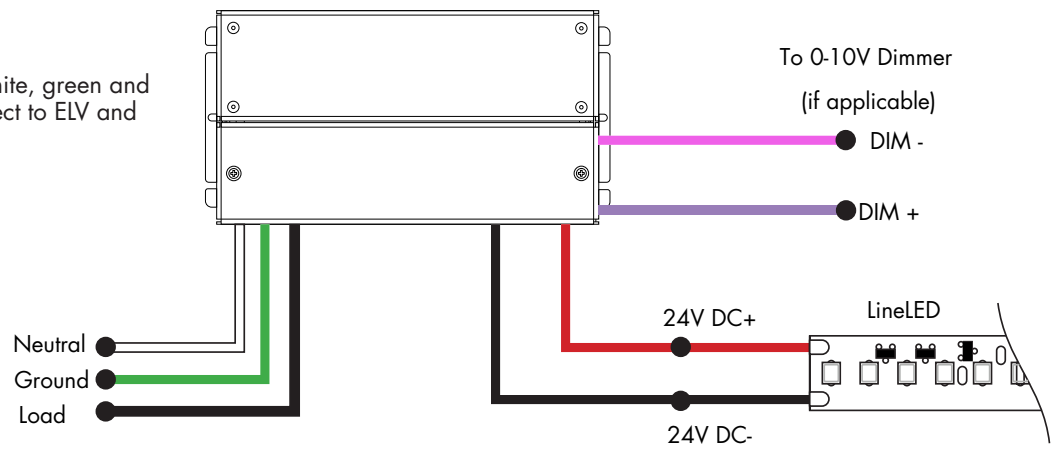

To 0-10V Dimmer (if applicable)
● DIM -
● DIM +

24V DC+
24V DC-

LineLED

5

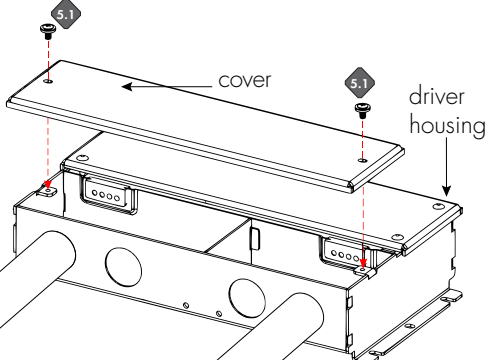

5.1 Insert the wire nut connections in the driver housing using waterproof wire nuts and close housing cover. Secure by tightening the two screws.