

# STENOS INSTALLATION INSTRUCTIONS

Surface Track



7777 Merrimac Ave  
Niles, IL 60714  
T 224.333.6033  
F 224.757.7557  
info@luminii.com  
www.luminii.com

**READ ALL OF THESE INSTALLATION INSTRUCTIONS BEFORE INSTALLING THE TRACK SYSTEM.  
SAVE THESE INSTRUCTIONS AND REFER TO THEM WHEN ADDITIONS TO OR CHANGES IN THE TRACK CONFIGURATION ARE MADE**

1. Product to be installed by a qualified electrician
2. Use only with class 2 power unit
3. 24 Volts DC
4. Suitable for dry locations only
5. 96W max, 24ft max, and 3 Electrical Joiners max per power feed.
6. Mechanical Joiners and End Cap isolate power circuits. Electrical Joiners are used to continue power down the track.
7. System shapes and power feed locations shown are for reference only. Refer to custom drawing package for the particulars of a specific custom system.

REVO.6  
11132023

1 / 17

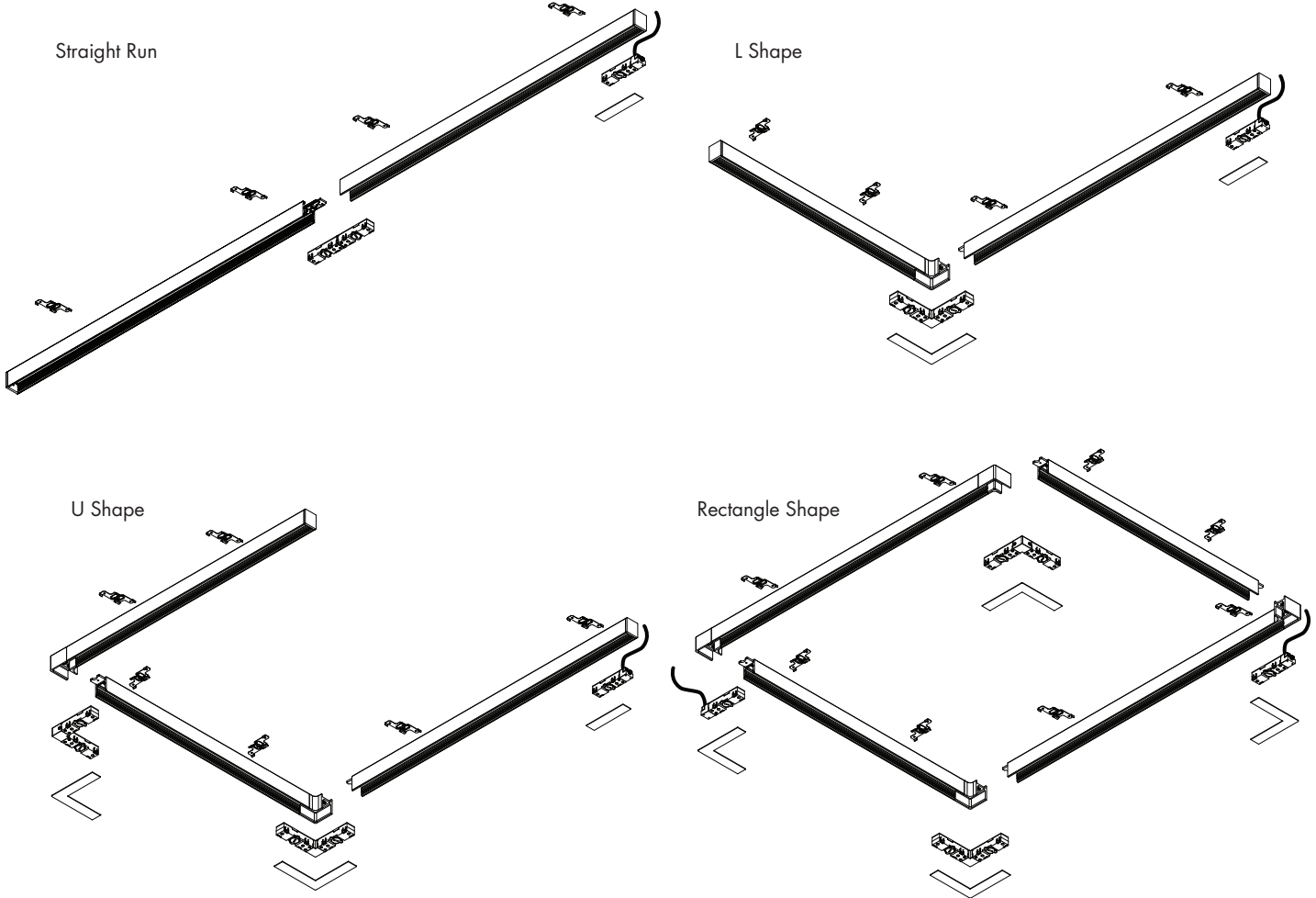

## Table of Contents

Section	Page
Straight Run	2
L Shape	6
U Shape	10
Rectangle Shape	14



## IMPORTANT SAFETY INSTRUCTIONS! SAVE THESE INSTRUCTIONS!

TRACK IS ONLY TO BE USED WITH OTHER ELECTRICAL FITTINGS IDENTIFIED FOR USE WITH THE TRACK SYSTEM. WHEN INSTALLING OR USING THIS TRACK SYSTEM, BASIC SAFETY PRECAUTIONS SHOULD ALWAYS BE FOLLOWED, INCLUDING:

- A. READ ALL INSTRUCTIONS.
- B. FOR USE WITH STENOS SURFACE (STS) TRACK SYSTEM ONLY
- C. DO NOT CUT ANY TRACK SECTIONS
- D. DO NOT INSTALL THIS TRACK IN DAMP OR WET LOCATIONS.
- E. DO NOT INSTALL ANY PART OF THE TRACK SYSTEM LESS THAN 5 FEET ABOVE THE FLOOR.
- F. DO NOT INSTALL ANY LUMINAIRE ASSEMBLY CLOSER THAN 6 INCHES FROM ANY CURTAIN, OR SIMILAR COMBUSTIBLE MATERIAL.
- G. DISCONNECT ELECTRICAL POWER BEFORE ADDING TO OR CHANGING THE CONFIGURATION OF THE TRACK.
- H. DO NOT ATTEMPT TO ENERGIZE ANYTHING OTHER THAN LIGHTING TRACK LUMINAIRES ON THE TRACK. TO REDUCE THE RISK OF FIRE AND ELECTRIC SHOCK, DO NOT ATTEMPT TO CONNECT POWER TOOLS, EXTENSION CORDS, APPLIANCES, AND THE LIKE TO THE TRACK.

# STENOS INSTALLATION INSTRUCTIONS

## Surface Track

**READ ALL OF THESE INSTALLATION INSTRUCTIONS BEFORE INSTALLING THE TRACK SYSTEM.  
SAVE THESE INSTRUCTIONS AND REFER TO THEM WHEN ADDITIONS TO OR CHANGES IN THE TRACK CONFIGURATION ARE MADE**

1. Product to be installed by a qualified electrician
2. Use only with class 2 power unit
3. 24 Volts DC
4. Suitable for dry locations only
5. 96W max, 24ft max, and 3 Electrical Joiners max per power feed.
6. Mechanical Joiners and End Cap isolate power circuits. Electrical Joiners are used to continue power down the track.
7. System shapes and power feed locations shown are for reference only. Refer to custom drawing package for the particulars of a specific custom system.



**luminii**

7777 Merrimac Ave  
Niles, IL 60714  
T 224.333.6033  
F 224.757.7557  
info@luminii.com  
www.luminii.com

REVO.6  
11132023

2 / 17

## S - Surface Track – Straight Run

### Track Installation Sequence

#### ATTENTION!

Make sure to install the tracks in the order that are specified on this page.

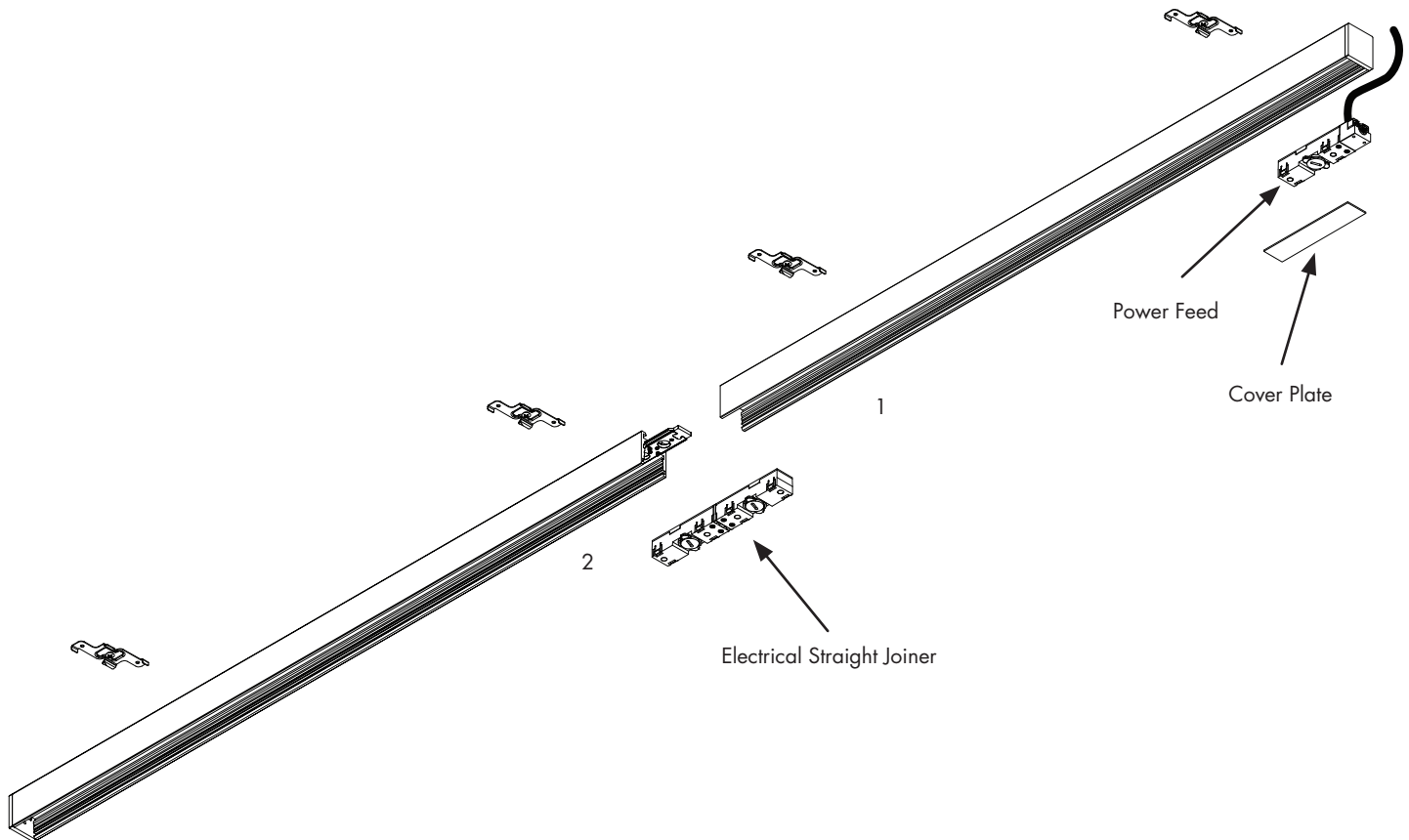

# STENOS INSTALLATION INSTRUCTIONS

## Surface Track



7777 Merrimac Ave  
Niles, IL 60714  
T 224.333.6033  
F 224.757.7557  
info@luminii.com  
www.luminii.com

REVO.6  
11132023

3 / 17

**READ ALL OF THESE INSTALLATION INSTRUCTIONS BEFORE INSTALLING THE TRACK SYSTEM. SAVE THESE INSTRUCTIONS AND REFER TO THEM WHEN ADDITIONS TO OR CHANGES IN THE TRACK CONFIGURATION ARE MADE**

1. Product to be installed by a qualified electrician
2. Use only with class 2 power unit
3. 24 Volts DC
4. Suitable for dry locations only
5. 96W max, 24ft max, and 3 Electrical Joiners max per power feed.
6. Mechanical Joiners and End Cap isolate power circuits. Electrical Joiners are used to continue power down the track.
7. System shapes and power feed locations shown are for reference only. Refer to custom drawing package for the particulars of a specific custom system.

## Marking location and installing mounting brackets

**S**

Track Length	# of Brackets
4ft	3
8ft	4
12ft	6

**S.1** IMPORTANT! Brackets are to be mounted 3-4" from the end of the track, and spaced apart no greater than 30". Take care to measure and mark where you want to place ceiling brackets before drilling into wall or ceiling

**S.2** For each mounting bracket. Drill a hole into the drywall using 13/64 drillbit and insert drywall anchor. Screw the mounting bracket into the anchor using a #6 screw. If installing to a hollow ceiling or concrete, must use a #6 screw size anchor that is rated for a minimum of 30lbs. For Powerfeed routing, drill a hole into the drywall using 3/8" drillbit.

**S.3** Route Power Feed Cable through pre-drilled hole in track. Snap Power Feed Connector into Track. Rotate locking cam, securing Power Feed Connector to track. Do not over-rotate locking cam. Place magnetic Cover Plate over Power Feed Connector.

**S.4** Route Power Feed Cable through hole in ceiling and make connection to power supply or junction box (by others).

**S.5** Assemble track section 1 to the mounting brackets. The brackets are rotated in a clockwise direction to lock into the rear of the track.

# STENOS INSTALLATION INSTRUCTIONS

Surface Track



**luminii**

7777 Merrimac Ave  
Niles, IL 60714  
T 224.333.6033  
F 224.757.7557  
info@luminii.com  
www.luminii.com

**READ ALL OF THESE INSTALLATION INSTRUCTIONS BEFORE INSTALLING THE TRACK SYSTEM.  
SAVE THESE INSTRUCTIONS AND REFER TO THEM WHEN ADDITIONS TO OR CHANGES IN THE TRACK CONFIGURATION ARE MADE**

1. Product to be installed by a qualified electrician
2. Use only with class 2 power unit
3. 24 Volts DC
4. Suitable for dry locations only
5. 96W max, 24ft max, and 3 Electrical Joiners max per power feed.
6. Mechanical Joiners and End Cap isolate power circuits. Electrical Joiners are used to continue power down the track.
7. System shapes and power feed locations shown are for reference only. Refer to custom drawing package for the particulars of a specific custom system.

REVO.6  
11132023

4 / 17

## Continuous Row Mounting (if applicable)

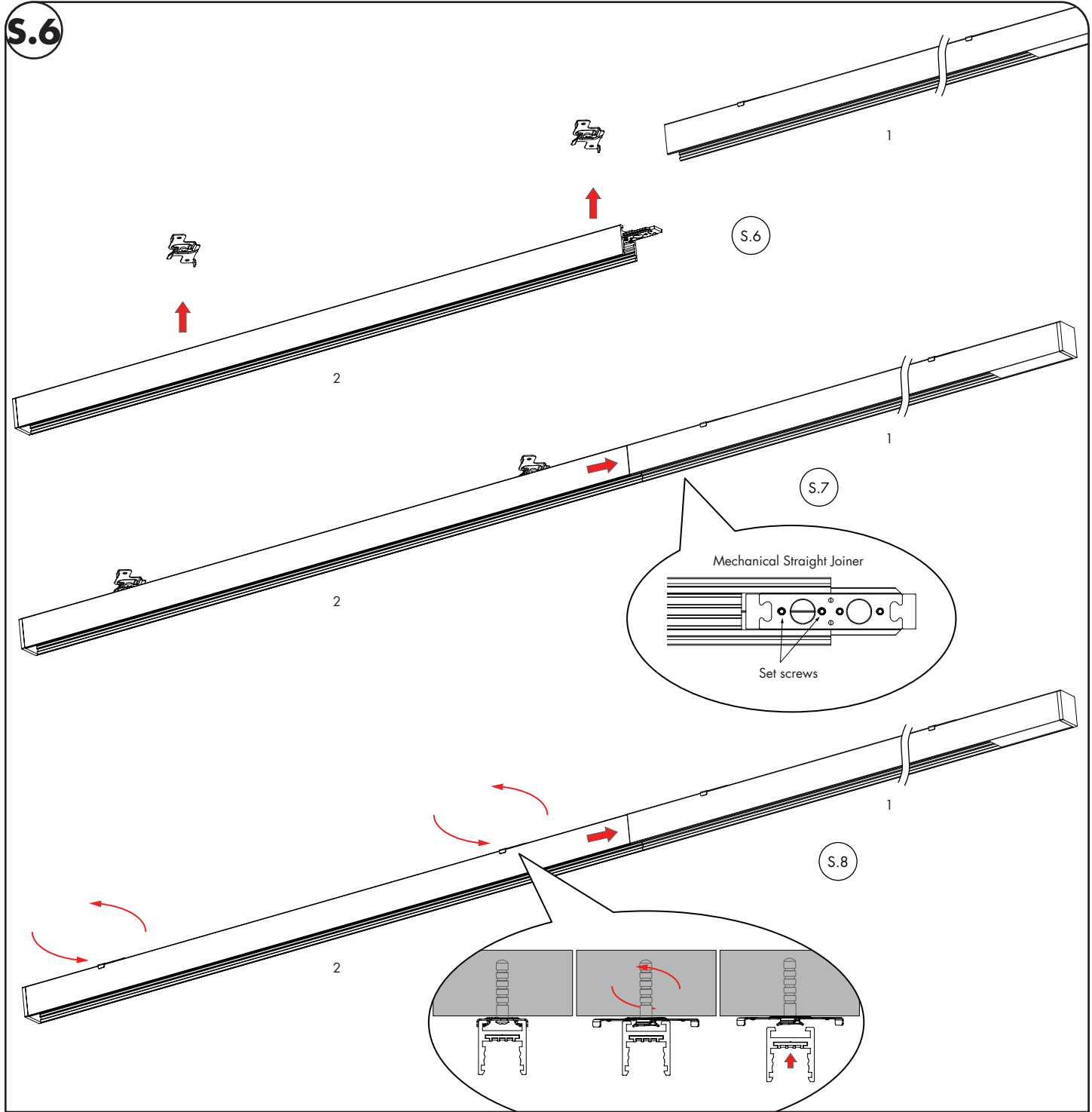

- S.6** Once track section 1 is attached to the surface, raise track section 2 making sure to line the track up neatly with the mounting brackets.
- S.7** Assemble track section 2 to track section 1 and tighten set screws on Mechanical Straight Joiner.
- S.8** Once the two tracks are connected, rotate mounting brackets to lock to surface.

# STENOS INSTALLATION INSTRUCTIONS

## Surface Track

READ ALL OF THESE INSTALLATION INSTRUCTIONS BEFORE INSTALLING THE TRACK SYSTEM.  
SAVE THESE INSTRUCTIONS AND REFER TO THEM WHEN ADDITIONS TO OR CHANGES IN THE TRACK CONFIGURATION ARE MADE

1. Product to be installed by a qualified electrician
2. Use only with class 2 power unit
3. 24 Volts DC
4. Suitable for dry locations only
5. 96W max, 24ft max, and 3 Electrical Joiners max per power feed.
6. Mechanical Joiners and End Cap isolate power circuits. Electrical Joiners are used to continue power down the track.
7. System shapes and power feed locations shown are for reference only. Refer to custom drawing package for the particulars of a specific custom system.



REVO.6  
11132023

5 / 17



7777 Merrimac Ave  
Niles, IL 60714  
T 224.333.6033  
F 224.757.7557  
info@luminii.com  
www.luminii.com

## Install Electrical Straight Joiners Magnetic Cover Plates (if continuous row mounting)

**S.9**

Stenos Track

Mechanical Straight Joiner

Dowel pins

Electrical Straight Joiner

Dowel pin holes

**S.9** Align Electrical Straight Joiner dowel pin holes with dowel pins of Mechanical Straight Joiner

**S.10**

**S.11**

**S.12**

Do not over-rotate locking cam.

**S.10** Snap Electrical Straight Joiner into Track

**S.11** Rotate locking cams, securing Electrical Straight Joiner to track. Do not over-rotate locking cam.

**S.12** Place magnetic Cover Plate over Electrical Straight Joiner

Perform a continuity check between the track conductors and the power cable to ensure that the power feed/joiner is sitting properly in the track.

# STENOS INSTALLATION INSTRUCTIONS

## Surface Track

**READ ALL OF THESE INSTALLATION INSTRUCTIONS BEFORE INSTALLING THE TRACK SYSTEM.  
SAVE THESE INSTRUCTIONS AND REFER TO THEM WHEN ADDITIONS TO OR CHANGES IN THE TRACK CONFIGURATION ARE MADE**

1. Product to be installed by a qualified electrician
2. Use only with class 2 power unit
3. 24 Volts DC
4. Suitable for dry locations only
5. 96W max, 24ft max, and 3 Electrical Joiners max per power feed.
6. Mechanical Joiners and End Cap isolate power circuits. Electrical Joiners are used to continue power down the track.
7. System shapes and power feed locations shown are for reference only. Refer to custom drawing package for the particulars of a specific custom system.



REVO.6  
11132023

6 / 17



7777 Merrimac Ave  
Niles, IL 60714  
T 224.333.6033  
F 224.757.7557  
info@luminii.com  
www.luminii.com

## L - Surface Track – L Shape

### Track Installation Sequence

#### ATTENTION!

Make sure to install the tracks in the order that are specified on this page.

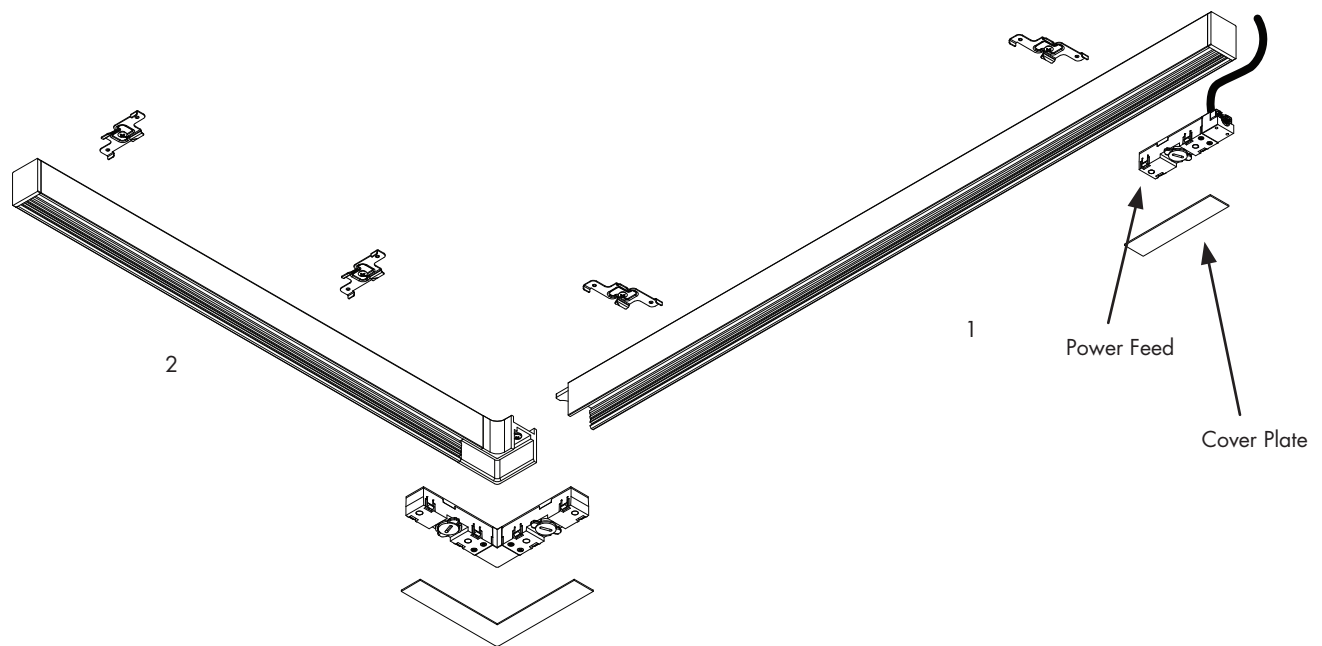

# STENOS INSTALLATION INSTRUCTIONS

## Surface Track



7777 Merrimac Ave  
Niles, IL 60714  
T 224.333.6033  
F 224.757.7557  
info@luminii.com  
www.luminii.com

REVO.6  
11132023

7 / 17

**READ ALL OF THESE INSTALLATION INSTRUCTIONS BEFORE INSTALLING THE TRACK SYSTEM. SAVE THESE INSTRUCTIONS AND REFER TO THEM WHEN ADDITIONS TO OR CHANGES IN THE TRACK CONFIGURATION ARE MADE**

1. Product to be installed by a qualified electrician
2. Use only with class 2 power unit
3. 24 Volts DC
4. Suitable for dry locations only
5. 96W max, 24ft max, and 3 Electrical Joiners max per power feed.
6. Mechanical Joiners and End Cap isolate power circuits. Electrical Joiners are used to continue power down the track.
7. System shapes and power feed locations shown are for reference only. Refer to custom drawing package for the particulars of a specific custom system.

## Marking location and installing mounting brackets

**L.1**

Track Length	# of Brackets
4ft	3
8ft	4
12ft	6

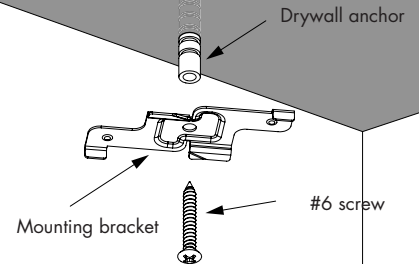
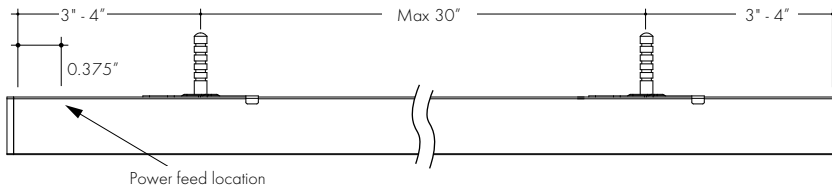

**L.1** IMPORTANT! Brackets are to be mounted 3-4" from the end of the track, and spaced apart no greater than 30". Take care to measure and mark where you want to place ceiling brackets before drilling into wall or ceiling

**L.2** For each mounting bracket. Drill a hole into the drywall using 13/64 drillbit and insert drywall anchor. Screw the mounting bracket into the anchor using a #6 screw. If installing to a hollow ceiling or concrete, must use a #6 screw size anchor that is rated for a minimum of 30lbs. For Power feed routing, drill a hole into the drywall using 3/8" drillbit.

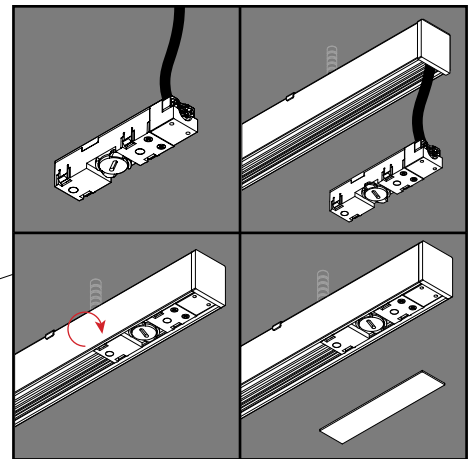
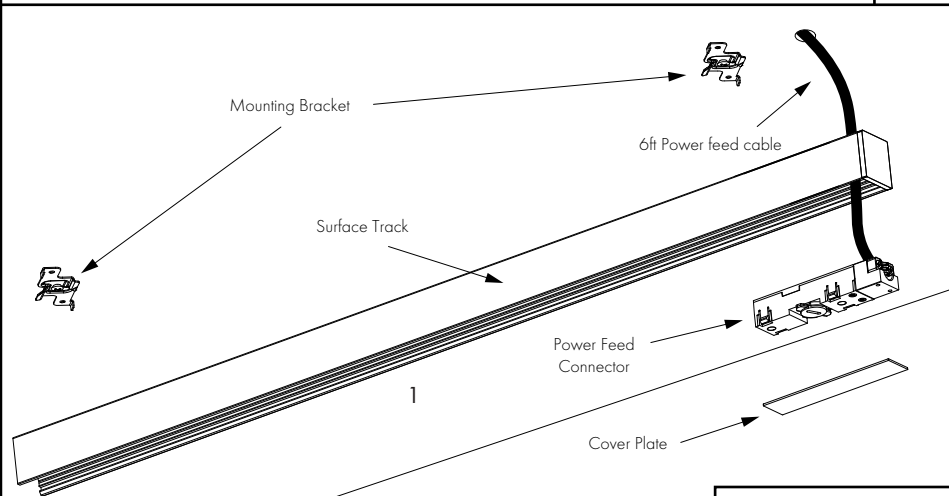

**L.3** Route Power Feed Cable through pre-drilled hole in track. Snap Power Feed Connector into Track. Rotate locking cam, securing Power Feed Connector to track. Do not over-rotate locking cam. Place magnetic Cover Plate over Power Feed Connector.

**L.4** Route Power Feed Cable through hole in ceiling and make connection to power supply or junction box (by others).

**L.5** Assemble track section 1 to the mounting brackets. The brackets are rotated in a clockwise direction to lock into the rear of the track.

If this leg consists of multiple track sections joined continuously, refer to steps S.6 - S.12 for continuous row mounting.

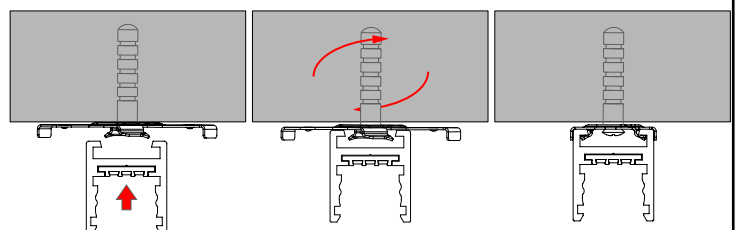
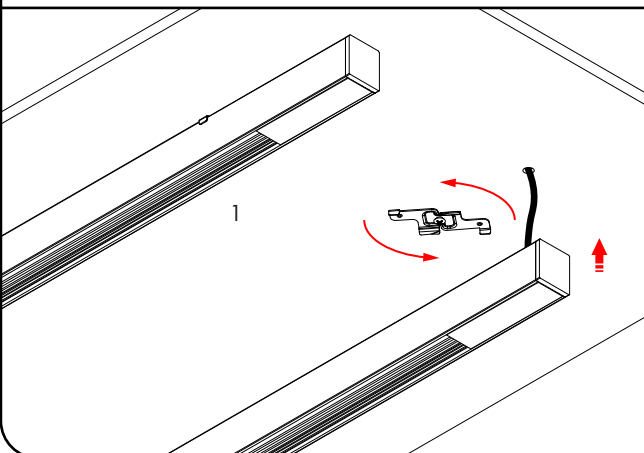

# STENOS INSTALLATION INSTRUCTIONS

## Surface Track

READ ALL OF THESE INSTALLATION INSTRUCTIONS BEFORE INSTALLING THE TRACK SYSTEM.  
SAVE THESE INSTRUCTIONS AND REFER TO THEM WHEN ADDITIONS TO OR CHANGES IN THE TRACK CONFIGURATION ARE MADE

1. Product to be installed by a qualified electrician
2. Use only with class 2 power unit
3. 24 Volts DC
4. Suitable for dry locations only
5. 96W max, 24ft max, and 3 Electrical Joiners max per power feed.
6. Mechanical Joiners and End Cap isolate power circuits. Electrical Joiners are used to continue power down the track.
7. System shapes and power feed locations shown are for reference only. Refer to custom drawing package for the particulars of a specific custom system.



7777 Merrimac Ave  
Niles, IL 60714  
T 224.333.6033  
F 224.757.7557  
info@luminii.com  
www.luminii.com

REVO.6  
11132023

8 / 17

Mount next track section to the ceiling and join to previous track section(s)

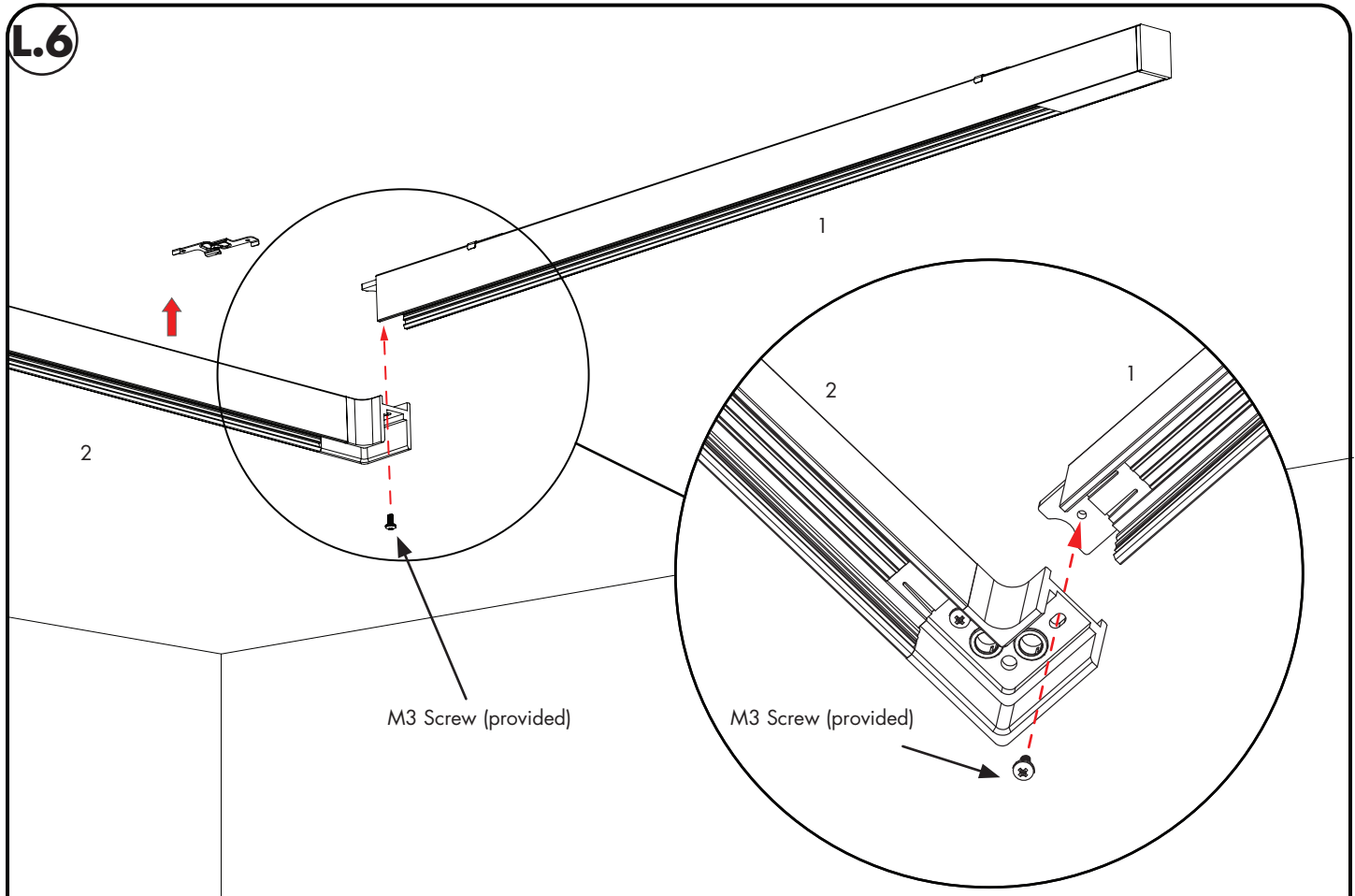

**L.6** Once track section 1 is attached to the surface, raise track section 2 making sure to line the track up neatly with the mounting brackets.

**L.7** Assemble track section 2 to track section 1 and tighten M3 screws (provided) on Mechanical L Joiner. Once the two tracks are connected, rotate mounting brackets to lock to surface (L.8). If this leg consists of multiple track sections joined continuously, refer to steps S.6 - S.12 for continuous row mounting.

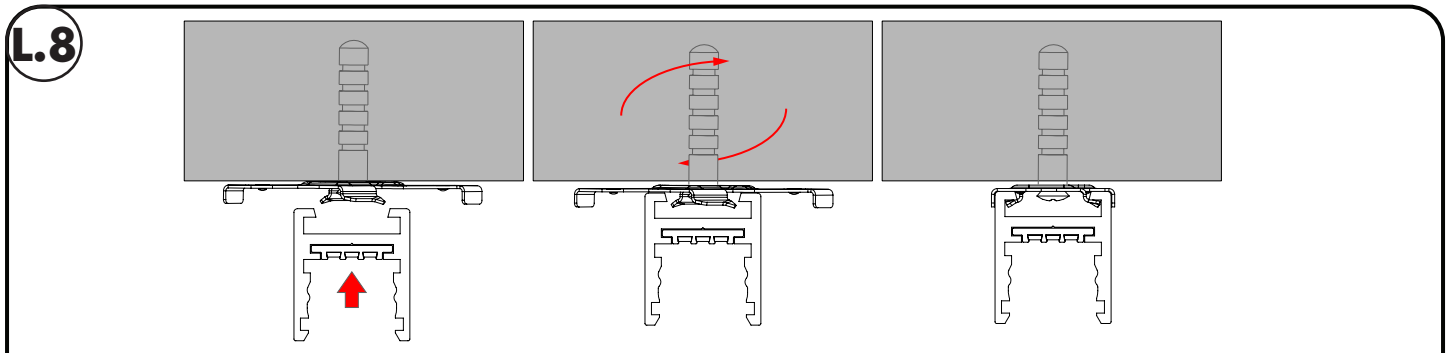

**L.8** Once the two tracks are connected, rotate mounting brackets to lock to surface.



# STENOS INSTALLATION INSTRUCTIONS

## Surface Track

**READ ALL OF THESE INSTALLATION INSTRUCTIONS BEFORE INSTALLING THE TRACK SYSTEM.  
SAVE THESE INSTRUCTIONS AND REFER TO THEM WHEN ADDITIONS TO OR CHANGES IN THE TRACK CONFIGURATION ARE MADE**

1. Product to be installed by a qualified electrician
2. Use only with class 2 power unit
3. 24 Volts DC
4. Suitable for dry locations only
5. 96W max, 24ft max, and 3 Electrical Joiners max per power feed.
6. Mechanical Joiners and End Cap isolate power circuits. Electrical Joiners are used to continue power down the track.
7. System shapes and power feed locations shown are for reference only. Refer to custom drawing package for the particulars of a specific custom system.



7777 Merrimac Ave  
Niles, IL 60714  
T 224.333.6033  
F 224.757.7557  
info@luminii.com  
www.luminii.com

REVO.6  
11132023

9 / 17

## Install Electrical L Joiner and Magnetic Cover Plates

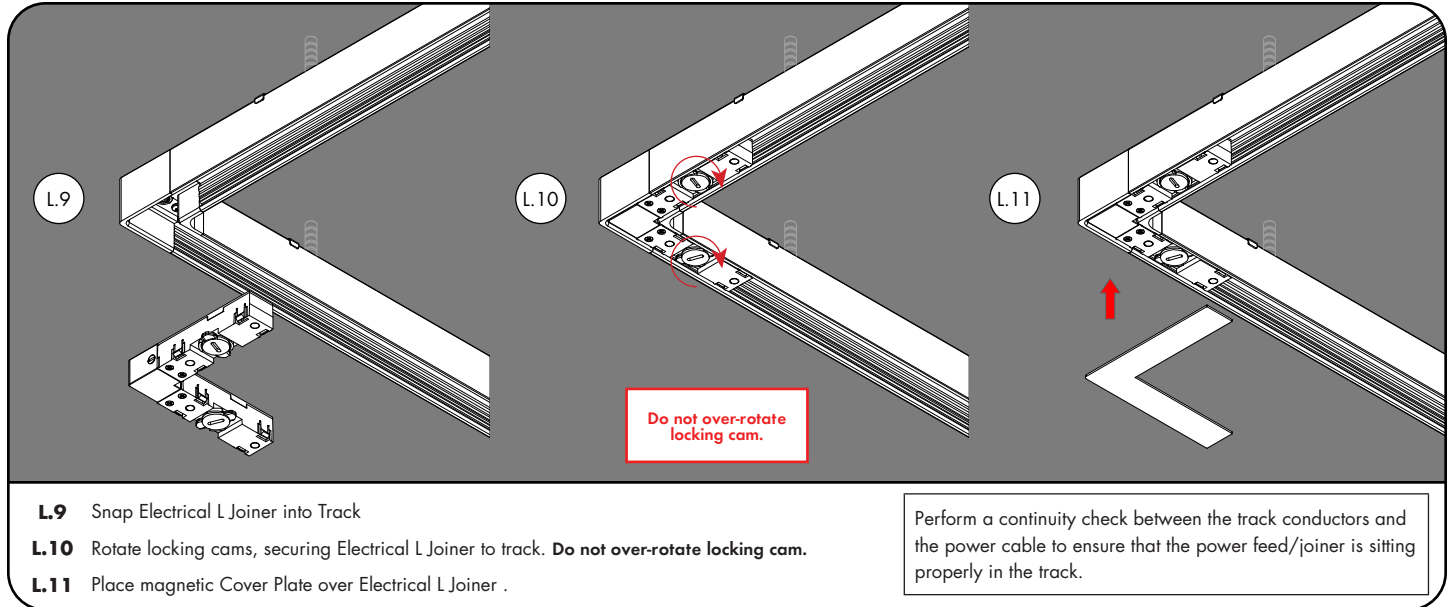

# STENOS INSTALLATION INSTRUCTIONS

## Surface Track

**READ ALL OF THESE INSTALLATION INSTRUCTIONS BEFORE INSTALLING THE TRACK SYSTEM.  
SAVE THESE INSTRUCTIONS AND REFER TO THEM WHEN ADDITIONS TO OR CHANGES IN THE TRACK CONFIGURATION ARE MADE**

1. Product to be installed by a qualified electrician
2. Use only with class 2 power unit
3. 24 Volts DC
4. Suitable for dry locations only
5. 96W max, 24ft max, and 3 Electrical Joiners max per power feed.
6. Mechanical Joiners and End Cap isolate power circuits. Electrical Joiners are used to continue power down the track.
7. System shapes and power feed locations shown are for reference only. Refer to custom drawing package for the particulars of a specific custom system.



REVO.6  
11132023

10 / 17



7777 Merrimac Ave  
Niles, IL 60714  
T 224.333.6033  
F 224.757.7557  
info@luminii.com  
www.luminii.com

## U – Surface Track – U Shape

### Track Installation Sequence

#### ATTENTION!

Make sure to install the tracks in the order that are specified on this page.

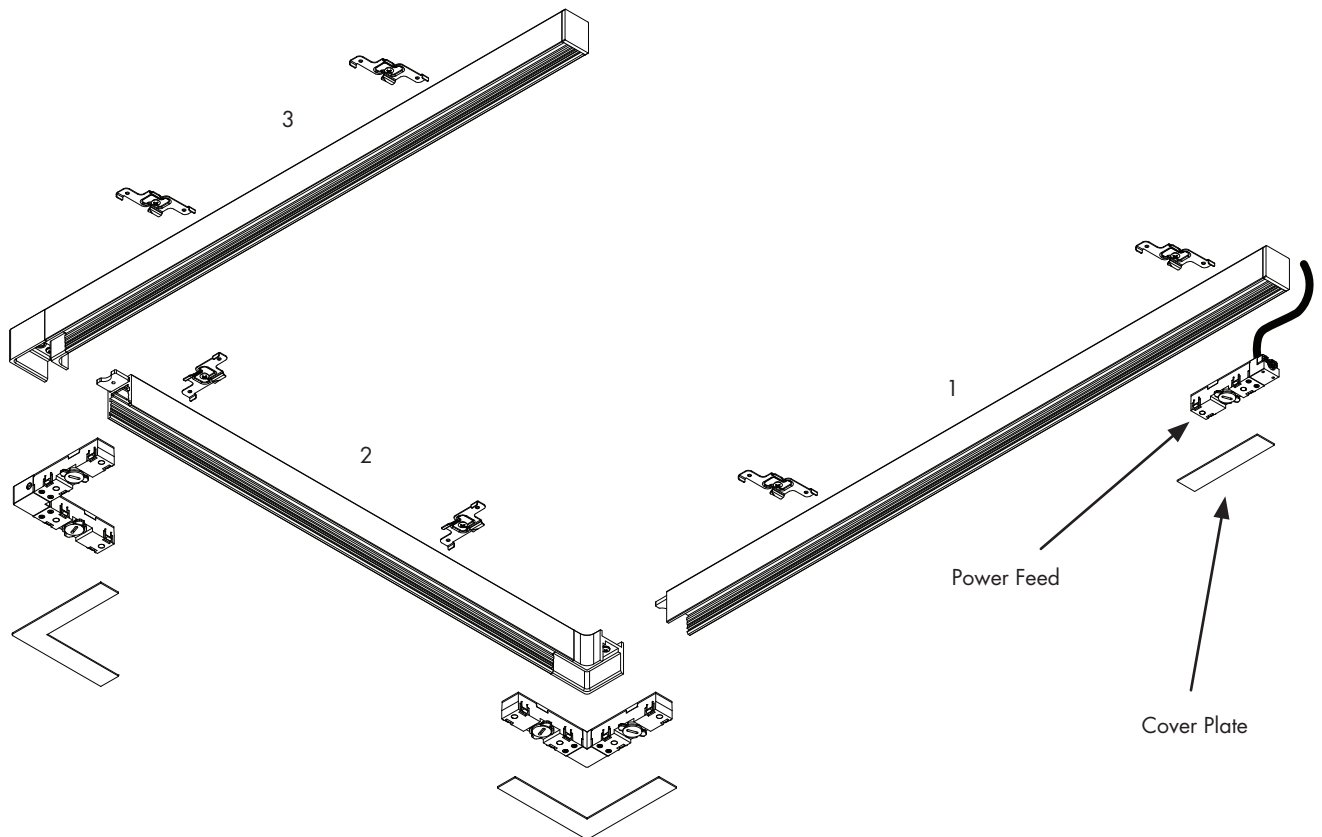

# STENOS INSTALLATION INSTRUCTIONS

## Surface Track



7777 Merrimac Ave  
Niles, IL 60714  
T 224.333.6033  
F 224.757.7557  
info@luminii.com  
www.luminii.com

REVO.6  
11132023

11 / 17

**READ ALL OF THESE INSTALLATION INSTRUCTIONS BEFORE INSTALLING THE TRACK SYSTEM. SAVE THESE INSTRUCTIONS AND REFER TO THEM WHEN ADDITIONS TO OR CHANGES IN THE TRACK CONFIGURATION ARE MADE**

1. Product to be installed by a qualified electrician
2. Use only with class 2 power unit
3. 24 Volts DC
4. Suitable for dry locations only
5. 96W max, 24ft max, and 3 Electrical Joiners max per power feed.
6. Mechanical Joiners and End Cap isolate power circuits. Electrical Joiners are used to continue power down the track.
7. System shapes and power feed locations shown are for reference only. Refer to custom drawing package for the particulars of a specific custom system.

## Marking location and installing mounting brackets

**U.1**

Track Length	# of Brackets
4ft	3
8ft	4
12ft	6

**U.1 IMPORTANT!** Brackets are to be mounted 3-4" from the end of the track, and spaced apart no greater than 30". Take care to measure and mark where you want to place ceiling brackets before drilling into wall or ceiling

**U.2** For each mounting bracket. Drill a hole into the drywall using 13/64 drillbit and insert drywall anchor. Screw the mounting bracket into the anchor using a #6 screw. If installing to a hollow ceiling or concrete, must use a #6 screw size anchor that is rated for a minimum of 30lbs. For Power feed routing, drill a hole into the drywall using 3/8" drillbit.

**U.3** Route Power Feed Cable through pre-drilled hole in track. Snap Power Feed Connector into Track. Rotate locking cam, securing Power Feed Connector to track. **Do not over-rotate locking cam.** Place magnetic Cover Plate over Power Feed Connector.

**U.4** Route Power Feed Cable through hole in ceiling and make connection to power supply or junction box (by others).

**U.5** Assemble the first section of track to the mounting brackets. The brackets are rotated in a clockwise direction to lock into the rear of the track.

If this leg consists of multiple track sections joined continuously, refer to steps S.6 - S.12 for continuous row mounting.

# STENOS INSTALLATION INSTRUCTIONS

## Surface Track

READ ALL OF THESE INSTALLATION INSTRUCTIONS BEFORE INSTALLING THE TRACK SYSTEM.  
SAVE THESE INSTRUCTIONS AND REFER TO THEM WHEN ADDITIONS TO OR CHANGES IN THE TRACK CONFIGURATION ARE MADE

1. Product to be installed by a qualified electrician
2. Use only with class 2 power unit
3. 24 Volts DC
4. Suitable for dry locations only
5. 96W max, 24ft max, and 3 Electrical Joiners max per power feed.
6. Mechanical Joiners and End Cap isolate power circuits. Electrical Joiners are used to continue power down the track.
7. System shapes and power feed locations shown are for reference only. Refer to custom drawing package for the particulars of a specific custom system.



**luminii**

7777 Merrimac Ave  
Niles, IL 60714  
T 224.333.6033  
F 224.757.7557  
info@luminii.com  
www.luminii.com

REVO.6  
11132023

12 / 17

Mount next track section to the ceiling and join to previous track section(s)

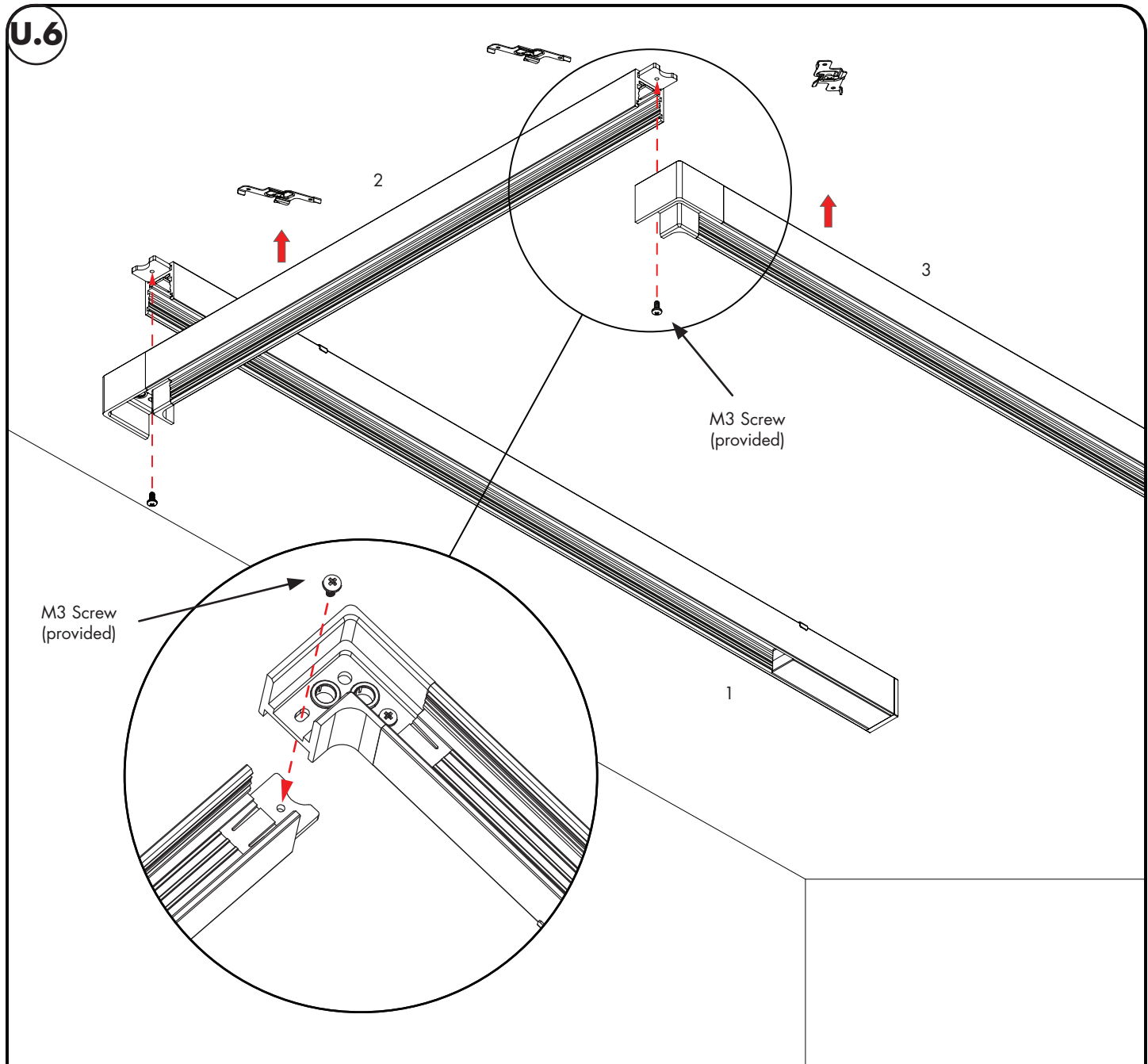

- U.6** Once track section 1 is attached to the surface, raise track section 2 making sure to line the track up neatly with the mounting brackets.
- U.7** Assemble track section 2 to track section 1 and tighten M3 screws (provided) on Mechanical L Joiner. Once the two tracks are connected, rotate mounting brackets to lock to surface (U.10). If this leg consists of multiple track sections joined continuously, refer to steps S.6 - S.12 for continuous row mounting.
- U.8** Raise track section 3 making sure to line the track up neatly with the mounting brackets.
- U.9** Assemble track section 3 to track section 2 and tighten M3 screws (provided) on Mechanical L Joiner. Once the two tracks are connected, rotate mounting brackets to lock to surface (U.10). If this leg consists of multiple track sections joined continuously, refer to steps S.6 - S.12 for continuous row mounting.

# STENOS INSTALLATION INSTRUCTIONS

Surface Track



7777 Merrimac Ave  
Niles, IL 60714  
T 224.333.6033  
F 224.757.7557  
info@luminii.com  
www.luminii.com

REVO.6  
11132023

13 / 17

**READ ALL OF THESE INSTALLATION INSTRUCTIONS BEFORE INSTALLING THE TRACK SYSTEM. SAVE THESE INSTRUCTIONS AND REFER TO THEM WHEN ADDITIONS TO OR CHANGES IN THE TRACK CONFIGURATION ARE MADE**

1. Product to be installed by a qualified electrician
2. Use only with class 2 power unit
3. 24 Volts DC
4. Suitable for dry locations only
5. 96W max, 24ft max, and 3 Electrical Joiners max per power feed.
6. Mechanical Joiners and End Cap isolate power circuits. Electrical Joiners are used to continue power down the track.
7. System shapes and power feed locations shown are for reference only. Refer to custom drawing package for the particulars of a specific custom system.

## Mounting track segments to the ceiling and join to previous tracks (cont.)

**U.10**

**U.10** Once the two tracks are connected, rotate mounting brackets to lock to surface.

## Install Electrical L Joiners Magnetic Cover Plates

**U.11**

**U.12**

Do not over-rotate locking cam.

**U.13**

**U.11** Snap Electrical L Joiners into Track

**U.12** Rotate locking cams, securing Electrical L Joiners to track. Do not over-rotate locking cam.

**U.13** Place magnetic Cover Plate over Electrical L Joiners.

Perform a continuity check between the track conductors and the power cable to ensure that the power feed/joiner is sitting properly in the track.

# STENOS INSTALLATION INSTRUCTIONS

## Surface Track

**READ ALL OF THESE INSTALLATION INSTRUCTIONS BEFORE INSTALLING THE TRACK SYSTEM.  
SAVE THESE INSTRUCTIONS AND REFER TO THEM WHEN ADDITIONS TO OR CHANGES IN THE TRACK CONFIGURATION ARE MADE**

1. Product to be installed by a qualified electrician
2. Use only with class 2 power unit
3. 24 Volts DC
4. Suitable for dry locations only
5. 96W max, 24ft max, and 3 Electrical Joiners max per power feed.
6. Mechanical Joiners and End Cap isolate power circuits. Electrical Joiners are used to continue power down the track.
7. System shapes and power feed locations shown are for reference only. Refer to custom drawing package for the particulars of a specific custom system.



**luminii**

7777 Merrimac Ave  
Niles, IL 60714  
T 224.333.6033  
F 224.757.7557  
info@luminii.com  
www.luminii.com

REVO.6  
11132023

14 / 17

## R – Surface Track – Rectangle

### Track Installation Sequence

#### ATTENTION!

Make sure to install the tracks in the order that are specified on this page.

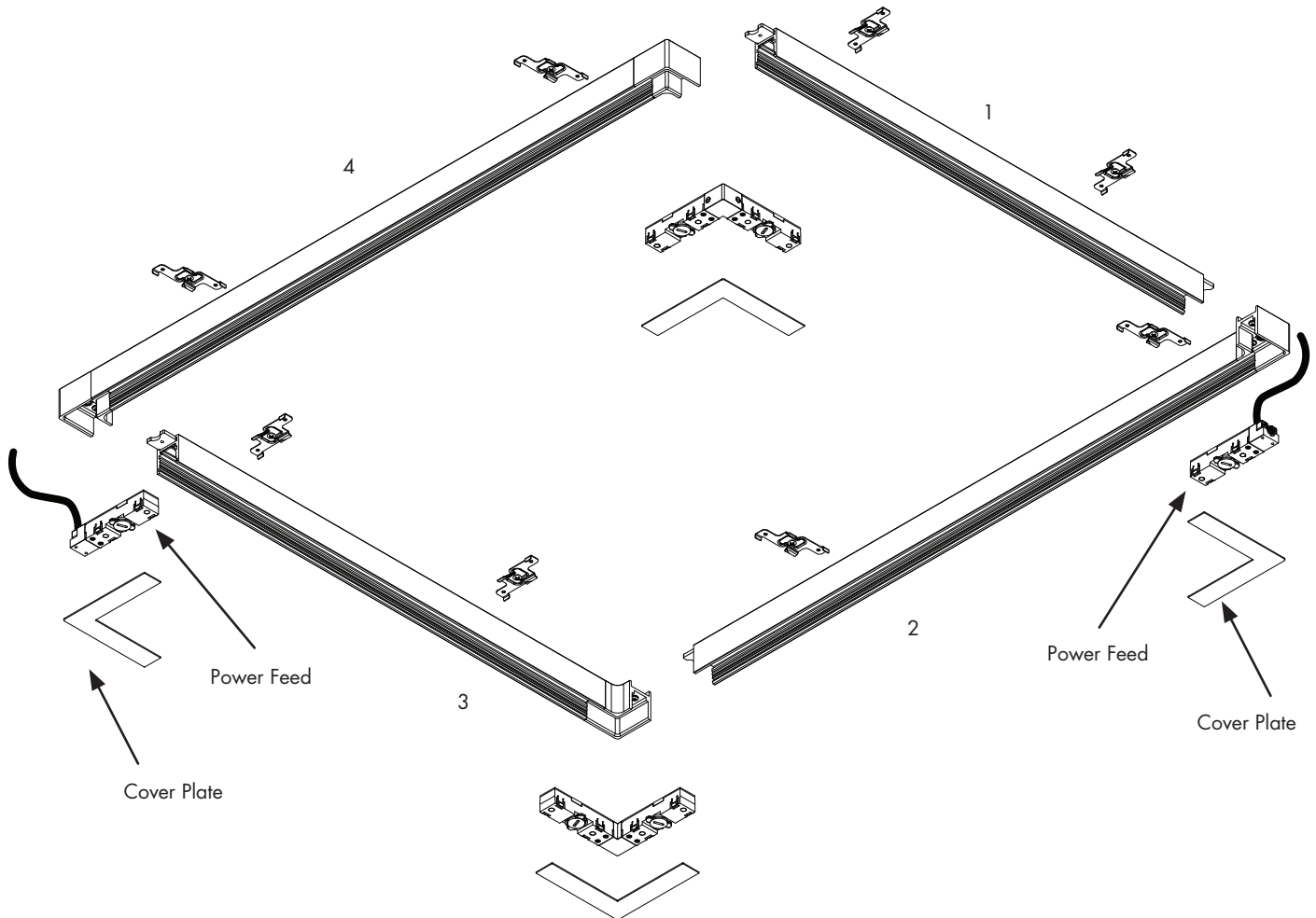

# STENOS INSTALLATION INSTRUCTIONS

## Surface Track



7777 Merrimac Ave  
Niles, IL 60714  
T 224.333.6033  
F 224.757.7557  
info@luminii.com  
www.luminii.com

REVO.6  
11132023

15 / 17

**READ ALL OF THESE INSTALLATION INSTRUCTIONS BEFORE INSTALLING THE TRACK SYSTEM. SAVE THESE INSTRUCTIONS AND REFER TO THEM WHEN ADDITIONS TO OR CHANGES IN THE TRACK CONFIGURATION ARE MADE**

1. Product to be installed by a qualified electrician
2. Use only with class 2 power unit
3. 24 Volts DC
4. Suitable for dry locations only
5. 96W max, 24ft max, and 3 Electrical Joiners max per power feed.
6. Mechanical Joiners and End Cap isolate power circuits. Electrical Joiners are used to continue power down the track.
7. System shapes and power feed locations shown are for reference only. Refer to custom drawing package for the particulars of a specific custom system.

## Marking location and installing mounting brackets

**R.1**

Track Length	# of Brackets
4ft	3
8ft	4
12ft	6

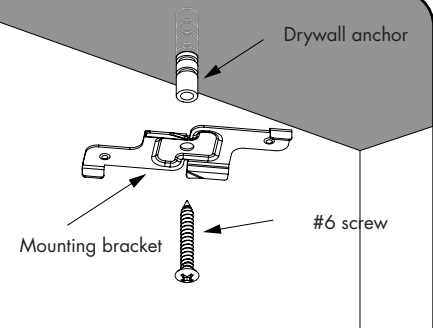
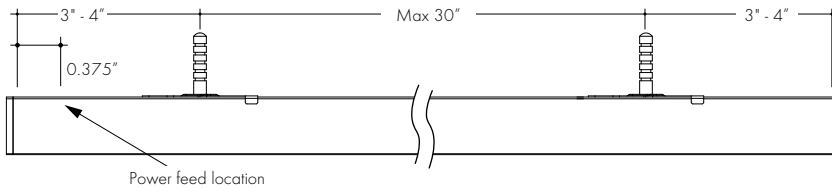

**R.1** IMPORTANT! Brackets are to be mounted 3-4" from the end of the track, and spaced apart no greater than 30". Take care to measure and mark where you want to place ceiling brackets before drilling into wall or ceiling

**R.2** For each mounting bracket. Drill a hole into the drywall using 13/64 drillbit and insert drywall anchor. Screw the mounting bracket into the anchor using a #6 screw. If installing to a hollow ceiling or concrete, must use a #6 screw size anchor that is rated for a minimum of 30lbs. For Power feed routing, drill a hole into the drywall using 3/8" drillbit.

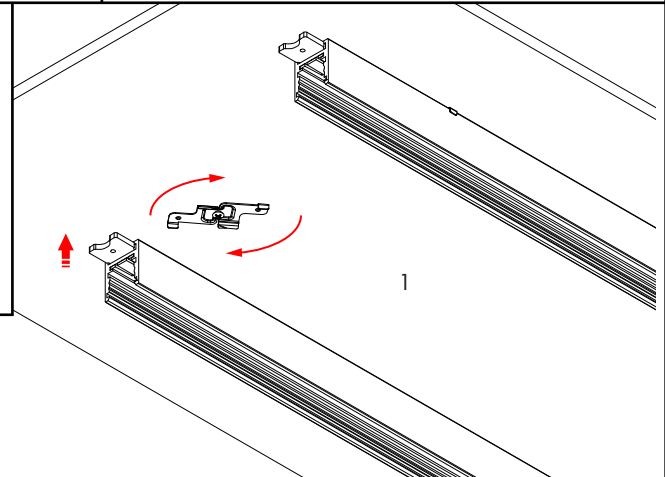
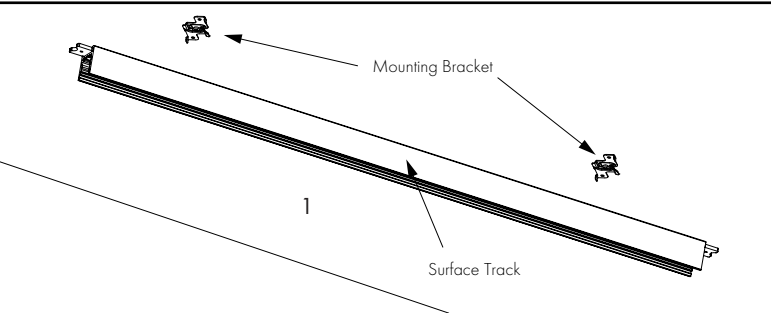

**R.3** Once mounting brackets are screwed onto the selected surface, assemble the track section 1 to the mounting brackets. The brackets are rotated in a clockwise direction to lock into the rear of the track.

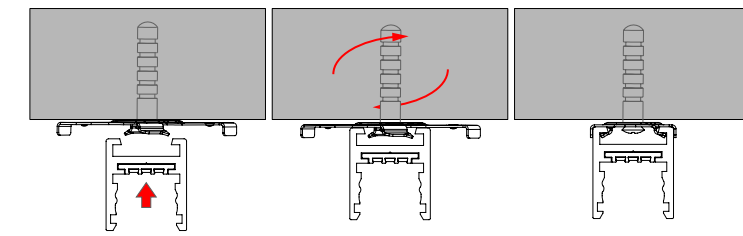

**R.4** Route Power Feed Cables through pre-drilled holes in track sections 2 and 4. Snap Power Feed Connectors into tracks. Rotate locking cams, securing Power Feed Connectors to track. **Do not over-rotate locking cam.**

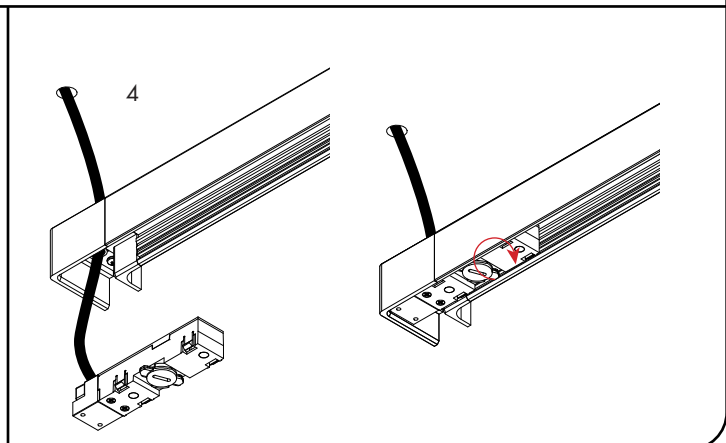
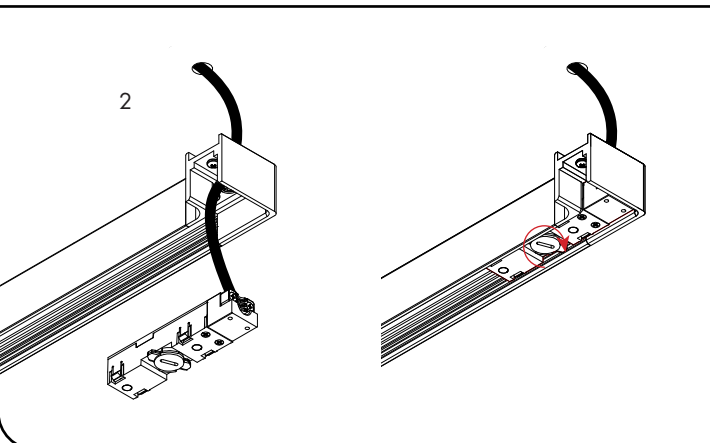

# STENOS INSTALLATION INSTRUCTIONS

## Surface Track



**luminii**

7777 Merrimac Ave  
Niles, IL 60714  
T 224.333.6033  
F 224.757.7557  
info@luminii.com  
www.luminii.com

REVO.6  
11132023

16 / 17

**READ ALL OF THESE INSTALLATION INSTRUCTIONS BEFORE INSTALLING THE TRACK SYSTEM.  
SAVE THESE INSTRUCTIONS AND REFER TO THEM WHEN ADDITIONS TO OR CHANGES IN THE TRACK CONFIGURATION ARE MADE**

1. Product to be installed by a qualified electrician
2. Use only with class 2 power unit
3. 24 Volts DC
4. Suitable for dry locations only
5. 96W max, 24ft max, and 3 Electrical Joiners max per power feed.
6. Mechanical Joiners and End Cap isolate power circuits. Electrical Joiners are used to continue power down the track.
7. System shapes and power feed locations shown are for reference only. Refer to custom drawing package for the particulars of a specific custom system.

Mount next track section to the ceiling and join to previous track section(s)

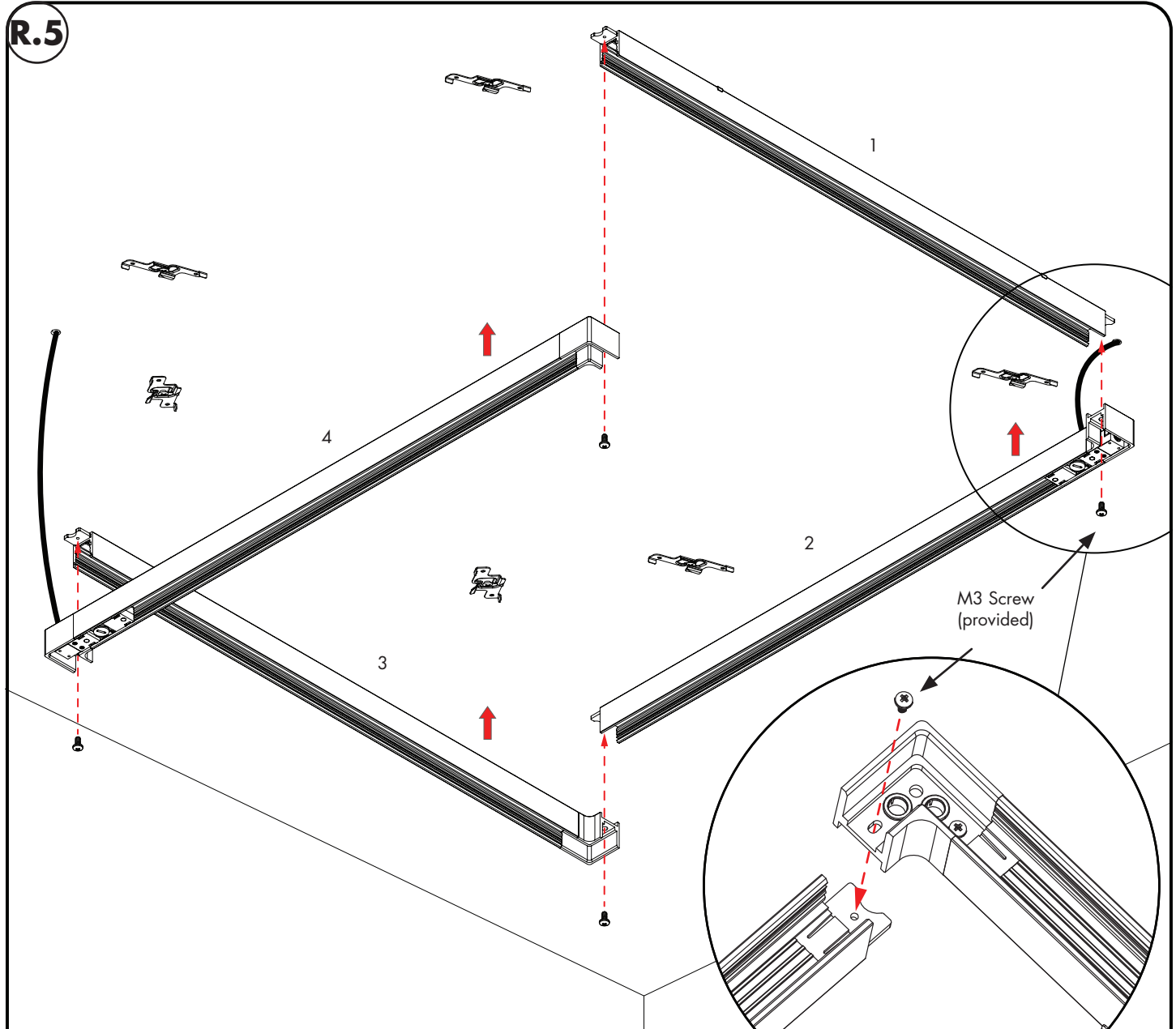

- R.5** Once track section 1 is attached to the surface, raise track section 2 making sure to line the track up neatly with the mounting brackets.
- R.6** Route Power Feed Cable of track section 2 through hole in ceiling and make connection to power supply or junction box (by others).
- R.7** Assemble track section 2 to track section 1 and tighten M3 screws (provided) on Mechanical L Joiner. Once the two tracks are connected, rotate mounting brackets to lock to surface (R.13). If this leg consists of multiple track sections joined continuously, refer to steps S.6 - S.12 for continuous row mounting.
- R.8** Raise track section 3 making sure to line the track up neatly with the mounting brackets.
- R.9** Assemble track section 3 to track section 2 and tighten M3 screws (provided) on Mechanical L Joiner. Once the two tracks are connected, rotate mounting brackets to lock to surface (R.13). If this leg consists of multiple track sections joined continuously, refer to steps S.6 - S.12 for continuous row mounting.
- R.10** Raise track section 4 making sure to line the track up neatly with mounting brackets.
- R.11** Route Power Feed Cable of track section 4 through hole in ceiling and make connection to power supply or junction box (by others).
- R.12** Assemble track section 4 to track section 3 and tighten M3 screws (provided) on Mechanical L Joiner. Once the two tracks are connected, rotate mounting brackets to lock to surface (R.13). If this leg consists of multiple track sections joined continuously, refer to steps S.6 - S.12 for continuous row mounting.



# STENOS INSTALLATION INSTRUCTIONS

Surface Track



7777 Merrimac Ave  
Niles, IL 60714  
T 224.333.6033  
F 224.757.7557  
info@luminii.com  
www.luminii.com

REVO.6  
11132023

17 / 17

**READ ALL OF THESE INSTALLATION INSTRUCTIONS BEFORE INSTALLING THE TRACK SYSTEM. SAVE THESE INSTRUCTIONS AND REFER TO THEM WHEN ADDITIONS TO OR CHANGES IN THE TRACK CONFIGURATION ARE MADE**

1. Product to be installed by a qualified electrician
2. Use only with class 2 power unit
3. 24 Volts DC
4. Suitable for dry locations only
5. 96W max, 24ft max, and 3 Electrical Joiners max per power feed.
6. Mechanical Joiners and End Cap isolate power circuits. Electrical Joiners are used to continue power down the track.
7. System shapes and power feed locations shown are for reference only. Refer to custom drawing package for the particulars of a specific custom system.

## Mounting track segments to the ceiling and join to previous tracks (cont.)

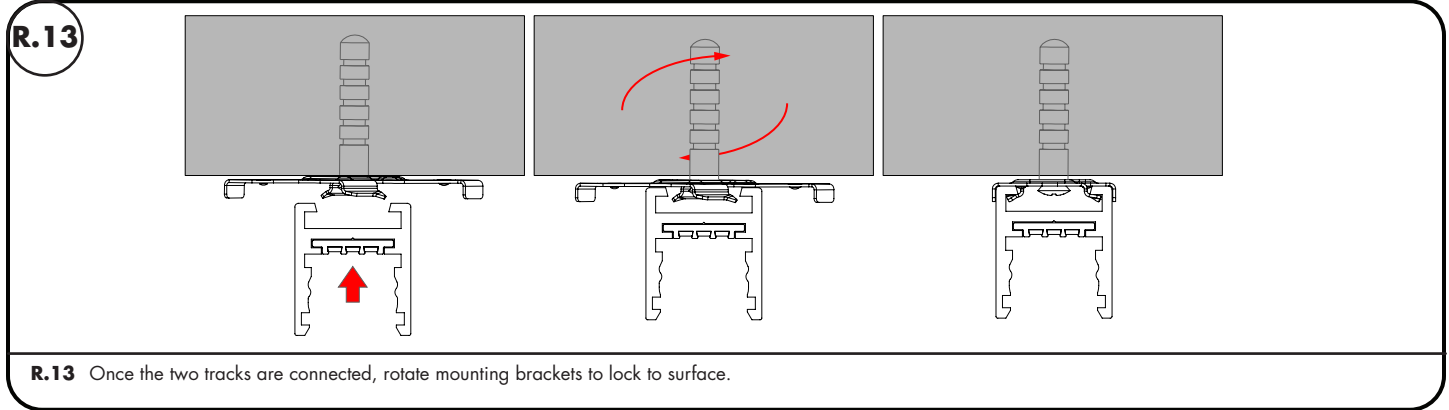

## Install Electrical L Joiners and Magnetic Cover Plates

